

6. Other machinery safety issues

6.1 Work organisation

For machine guarding to work effectively, the movement of materials on site and the job procedures related to the machinery must be thoroughly understood. Safe machinery operating procedures or instructions for machinery must be developed, and workers must be adequately trained to ensure safe work practices are maintained.

New risks should not be introduced into the workplace as a consequence of the introduction of new technology, machinery or plant, or modifications to existing machinery or plant. At these times, risk assessments must be performed. These should be carried out in consultation with workers.

6.1.1 Layout

Machine guarding will be more effective if it is used in conjunction with proper attention to layout. Machines that are poorly located or too close together may not be safe even if guarded.

Some basic points to consider in relation to layout are to:

- avoid congestions or worker movements near machinery that are likely to increase the risk of injury;
- eliminate or minimise hazardous movements in relation to operation, cleaning or maintenance, for example blockages;
- where waste materials are generated, include space for storage or accumulation until cleared. They should not be allowed to clutter walkways or work areas;
- consider 'traffic flow' by identifying the movements of trucks, materials and people. By defining simple, well marked and well understood traffic areas and directions, the likelihood of people coming near dangerous machinery, and therefore the risk of injury, can be reduced; and
- review proximity of moving parts near other machinery or plant and fixtures in buildings.

6.1.2 Housekeeping

Untidiness can cause slips, trips and falls. Injuries can be avoided by:

- keeping work areas, walkways and other access paths clear and clean. They should be clearly marked; and
- preventing spills, which may cause slips. Design machinery and work processes to minimise lubrication oil loss or spillage. Clean up spills as soon as possible and avoid any oily residues on the floor. Provide a rough anti-slip floor where this is not practical.

6.2 Safe work procedures

Employers must ensure there are safe systems of work and safe working procedures in relation to machinery and plant. These should address issues such as:

- the guarding on items and the need for it;
- instructions on procedure to operate plant when guards are removed;
- instructions on not removing the guarding. Systems should be in place to prevent workers from bypassing guarding mechanisms;
- instructions on safe access to and egress from machinery and plant;
- instructions on who may use an item of plant, for example only authorised workers;
- instructions on isolation and emergency stop devices (see the next section);
- instructions for inspections, cleaning, repair, maintenance and problems that may occur; and
- emergency procedures.

See also Part 3 of the OSH Regulations for requirements in relation to provision of water, air temperature and personal protective clothing and equipment.

When new machinery and plant are introduced into the workplace:

- safe work procedures and training must be provided where there are different operating requirements, for example when the controls on a new machine are in a different place to where operators are used to; and
- any documented work procedures and manuals should also be updated.

Adequate supervision must be provided to ensure safe work procedures are followed.

6.3 Isolation

When access to machinery or plant is required for inspections, repairs, maintenance, alterations and cleaning or the plant is to be withdrawn for assessment or repair, there are general and specific requirements for employers and their 'authorised person' for the isolation of the machinery or plant from energy sources and general safety.

The employer, main contractor or self-employed person must ensure that there is a safe system of isolating the energy sources for all machinery and plant.

As part of establishing a safe system of isolation, it must be ensured that:

- there are procedures for preparing a machine for the application of isolation devices, locks and tags as practicable — see the box below;
- workers are adequately instructed and trained in the system and can demonstrate that they are competent to carry out the isolation or lock out and tag out procedures; and
- adequate supervision is provided to ensure that the isolation procedures, including those outlined below, are followed.

Workers trained in the safe system of isolation for machinery and plant must ensure that it is followed at all times.

See also the Commission's *Guidance note: Isolation of plant.*

For non-mining workplaces, see regulation 4.37A of the OSH Regulations. For mining workplaces, see regulation 6.27 of the MSI Regulations.

Isolation procedures

For non-mining workplaces, see regulation 4.37A(2) of the OSH Regulations. For mining workplaces, see regulation 6.2, 6.21 and 6.27 of the MSI Regulations.

There must be a procedure for the isolation of each piece of machinery or plant, including the application of isolation devices, locks and tags, as practicable. While a specific procedure for a machine may differ because of different situations, the following steps must be included in the isolation procedure.

When carrying out checks, tests, inspections, maintenance, alteration or cleaning or when the plant is to be withdrawn from use because of an immediate risk, the employer, main contractor, self-employed person or person having control of the workplace or its access must:

- ensure that all the hazards associated with all energy sources of the plant are identified. This may involve a comprehensive examination of the equipment's operational safety manual or consulting competent people such as engineers; and
- authorise a person ('the authorised person') to carry out the matters outlined below.

The authorised person must, if it is practicable to do so, stop the plant and ensure any risks associated with any identified hazards are reduced as far as practicable. This should include notifying any workers who may be affected by the planned isolation that it is about to occur. The authorised person must then, if it is practicable, ensure:

- a) all energy sources are de-energised and isolated using an isolation device and locked out using a lock-out device. This step should include activating all energy isolating devices and ensuring all switches and valves are in the off or safe position as part of measures to stop any attempts to activate the machine. It may include release or restraint of stored energy including, for example, completing the cycle of a flywheel, releasing steam and bleeding valves;
- b) an out-of-service tag is fixed to the plant and danger tags are fixed at the energy sources and the operating controls of the plant;
- c) the measures taken to de-energise and isolate the energy sources are tested to ensure the plant cannot be energised inadvertently;
- d) any inspection, repair, maintenance, alterations or cleaning of plant or withdrawal of it is not carried out before the above tests are carried out; and
- e) after the above work is carried out, the plant is returned to operational status. The worker who isolated the machinery should remove the lockout equipment. A procedure should be in place for cases where this is not possible, for example where work is conducted over a number of shifts or the worker has gone home sick.

If it is not practicable to carry out all of the matters in (a)-(d), then:

- the authorised person must ensure that those matters that are practicable are carried out; and
- the person who gave the authorised person authorisation must ensure that:
 - written procedures are developed by a competent person to deal with the hazards and energy sources that it has not been practicable to deal with under (a)-(d);
 - the written procedures are provided to the authorised person; and
 - the written procedures are followed by the person who is carrying out the inspection, repair, maintenance, alteration and cleaning of plant or withdrawing of it from use.

If access to plant is required for inspection, repair, maintenance, alteration or cleaning or to withdraw it because of an immediate risk to safety and health and it is not practicable to stop it, the employer, main contractor, self-employed person or person having control of the workplace or its access must ensure that:

- the plant is fitted with operating controls that allow controlled movement of the plant;
- there are written procedures to be followed in relation to anything carried out for inspections, repairs, maintenance, alteration and cleaning of plant that are designed to prevent injury to people working on it or when it is withdrawn from use; and
- people working on the plant carry out the work in accordance with the written procedures.

For non-mining workplaces, see regulation 4.37(3) and (4) of the OSH Regulations. For mining workplaces, see regulations 6.2, 6.21 and 6.27 to 6.30 of the MSI Regulations.

For non-mining workplaces, see regulation 4.37A(5) of the OSH Regulations. For mining workplaces, see regulation 6.2, 6.21 and 6.27 of the MSI Regulations.

For non-mining workplaces, see regulation 4.37A(6) of the OSH Regulations. For mining workplaces, see regulation 6.2, 6.21 and 6.27 of the MSI Regulations.

Isolation devices must be reliable and clear. The method used to isolate plant will vary depending on the type of equipment. Chains, clasps and locks are examples of devices that can be used to isolate plant. For example, steel pins and metal support bars can be used to support vehicle hoists. These devices must be locked in place to ensure they cannot be removed by others when workers are working under them.

Machines may contain stored energy, for example in springs, closed hydraulic or pneumatic circuits, suspended components or materials or torque in shafts. There must be a method or procedure to release or contain this energy as part of the lockout procedure.

Each lock should:

- be strong enough to withstand physical abuse, either intentional or unintentional;
- be made of material suitable for the environment;
- be heavy duty or specifically designed; and
- have only one key and one owner who is responsible for it to prevent its removal without their knowledge.

Master or spare keys should be kept in a designated location, away from the immediate workplace, and under the control of an authorised person. There should be strict procedures to ensure they are only used in an emergency and after thorough safety checks have been made.

6.4 Emergency stop devices

Emergency stop devices should not be the only method of controlling hazards. They should be used only as a backup to other control measures.

When choosing an emergency stop device, it is important to conduct a risk assessment to consider if:

- part of the machine may still need to operate, for example in an emergency situation;
- other safety features may still need to operate, for example pressure release valves; and
- any additional hazards may be introduced.

A risk assessment will assist in determining the level of integrity of associated circuitry. Where additional information is required see Australian Standard, *AS 4024.1501 Safety of machinery: Part 1501: Design of safety related parts of control systems — General principles for design*.

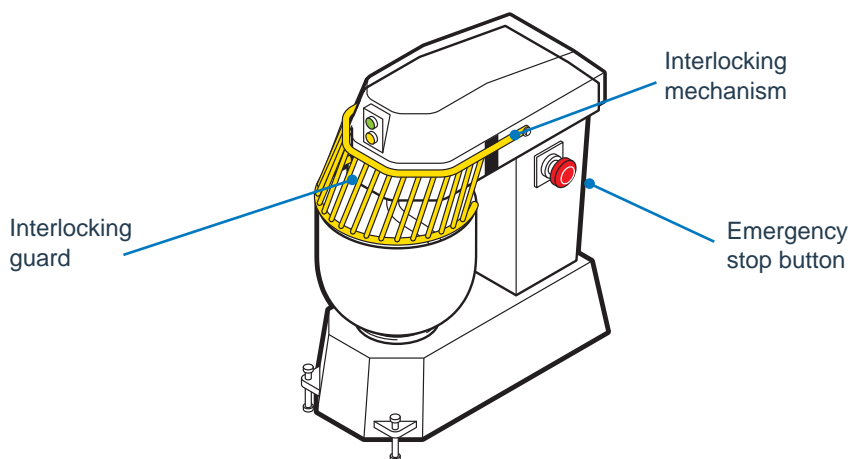

Illustration 32. Food mixer with emergency stop button.
Yellow = interlocked guarding. Red = emergency stop button.

For non-mining workplaces, see regulation 4.29(m) of the OSH Regulations. For mining workplaces, see regulation 6.2(2)(j) of the MSI Regulations.

Emergency stop devices

Ensure emergency stop devices are:

- prominent, clearly and durably marked and immediately accessible to each operator of the plant;
- have handles, bars or push buttons that are coloured red. Labelling can also be used. Consider installing ones that protrude and are not level with the surrounds; and
- not affected by electrical or electronic circuit malfunction.

Other considerations include:

- the best access for workers;
- the environment the machine is used in, for example whether there could be exposure to dust, chemicals, extremes of temperature or vibration;
- the number of emergency stop devices required. If the machine or plant is large, several devices or pull wires may be necessary;
- a manual procedure for resetting an emergency stop device. They should not be affected by electrical or electronic circuit malfunction; and
- testing at regular intervals to ensure they have not ceased functioning.

Poorly located emergency stop devices may delay shutdown in an emergency and encourage dangerous practices, such as:

- reaching across moving parts;
- a failure to shut down machinery or plant when a problem occurs; or
- situations where the machine or plant can be started by one worker while another is in a dangerous location, for example cleaning a bin.

When there are multiple devices, safe operating practices should be adopted so that machinery or plant is not restarted when it is undergoing maintenance or other temporary operations. A lock-out and tag-out system, as outlined above, is therefore an essential part of isolating an energy source to prevent accidental plant start up.

6.5 Controls and buttons

Where possible, manual control devices should:

- be designed and located according to ergonomic design principles — see Appendix 5;
- have a stop control device near each start control device;
- be located out of danger zones except where there is a necessary requirement, for example an emergency stop;
- be marked to indicate their nature and function;
- be located with the operator's control position so the operator is able to see the working area or hazard zone;
- not be able to be accidentally started; and
- where there is more than one control to start a high risk part of the plant, be arranged so that only one control can work at a time.

6.6 Inspection, cleaning, repair, maintenance and emergency procedures

To safeguard operators and other workers during inspections, cleaning, repairing, maintenance and emergencies:

- apply isolation procedures whenever maintenance or repair requires people to enter the danger area around machinery — see also Section 6.3 of this code;
- cleaning, repair, maintenance and emergency procedures should be in place and understood by workers;
- a regular inspection regime should be in place to identify any problems with machinery or plant and safeguards;
- any additional hazards associated with inspections, cleaning, repair, maintenance and emergencies should be identified and assessed as part of the risk management process; and
- special precautions need to be taken where workers are obscured while undertaking tasks, or where there are multiple operating switches.

6.7 Weight

Large machinery or plant may require extensive guarding and these guards may need to be removed for maintenance access. While some sections may remain fixed, it is preferable that the guarding be divided into easily removable sections. Sections should be designed to be removed and handled easily by one person.

Appropriate placement of handles on movable sections will facilitate ease of removal, lifting and handling and reduce the risk of manual handling injuries.

Where practicable, mechanical devices, such as cranes or other lifting devices, should be used to avoid manually moving heavy guards.

6.8 Movable guards

Guards that move out of the way for each operation (automatic guards) require special consideration.

Assess potential risks in the interactions:

- between **guard** and **machine**;
- between **guard** and **person**; and
- between **guard** and **work piece**.

6.9 Colour coding

It is good practice for all safety guards to be painted the same colour. For example:

- use high visibility yellow, provided it is different to the machine's colour, so that it can be clearly seen when a guard has been removed or when it is not in its proper place; and
- paint the surfaces behind the guard a contrasting or preferably bright colour, for example blue or red, so that when the guard has been removed, the exposed colour is clearly visible. It is then easy to identify that the guard has been removed and workers are alerted to possible danger.